



with HOT
(High Output
Technology)

The Ultimate in Air Disc Brake Performance & Durability

UL-Disc™



TSE innovated the double-diaphragm HOT (High Output Technology) chamber used worldwide for disc brake applications. Now TSE has taken disc brake actuators to the next level with the ultimate in product durability and corrosion resistance.

Introducing UL-Disc.

Innovative Design

UL-Disc features a 100% steel inverted spring bottom housing that reduces both spring coil-to-coil contact and spring coil-to-spring housing contact. The all-steel design provides a durable, air-tight center section that virtually eliminates leaks and structural failures, while the recessed pressure plate allows for a shorter and more compact chamber.

Tough Main Spring

UltraLife main spring adds a proprietary base coating in addition to TSE's multi-stage coating system for the ultimate in corrosion protection. Tested to double SAE standards, UL-Disc's main spring actually exceeds SAE dry cycle testing requirements in a slurry environment.

Superior Corrosion Resistance

With TSE's exclusive in-house process, all parts of the UL-Disc actuator receive a multi-stage pre-treatment prior to e-coat and an extra layer of polyester powder coating protection.

Premium Quality

TSE is an ISO 9001 and KBA certified company. As an OEM premium direct fit and aftermarket replacement, UL-Disc is the premium brake for your heavy-duty disc brake trucking application.

HOT (High Output Technology)

As the first double-diaphragm chamber used worldwide for disc brake applications, TSE's High Output Technology (HOT) chamber is a proven alternative to piston type disc brakes. HOT chambers offer higher output performance for your disc brake application when compared to standard double-diaphragm chambers, and at a lower cost than piston chambers. HOT brakes are ideal for replacing piston brakes that are typically used on buses and other severe-duty applications.

Complete In-House Testing

UL-Disc brake actuators undergo rigorous in-house testing in TSE's comprehensive testing lab. Tests include variable pressure cycle testing, vibration testing, hot cell cycle testing, salt spray testing, cold cell leak/operational testing and slurry testing.

Warranty

Industry leading warranty – up to 7 years.



The Ultimate in Air Disc Brake Performance & Durability

Full immersion electro-deposition coating inside and out and an exclusive powder coating finish for the most durable corrosion protection in the industry.

NEW: TSE All-n-One™ self guided recessed pressure plate. Diaphragms are factory sealed to pressure plate. Assures proper alignment to extend life of pressure plate, diaphragm and power spring.

UL-Disc features a unique composite port adapter. Reduces profile size. Easy air connection.

Patented bushing assembly provides center seal that traps lubricant for extended service, reducing center section leaks and brake drag.

Premium diaphragms feature high quality contaminant resistant rubber reinforced with nylon fabric tested well beyond the toughest industry specifications.

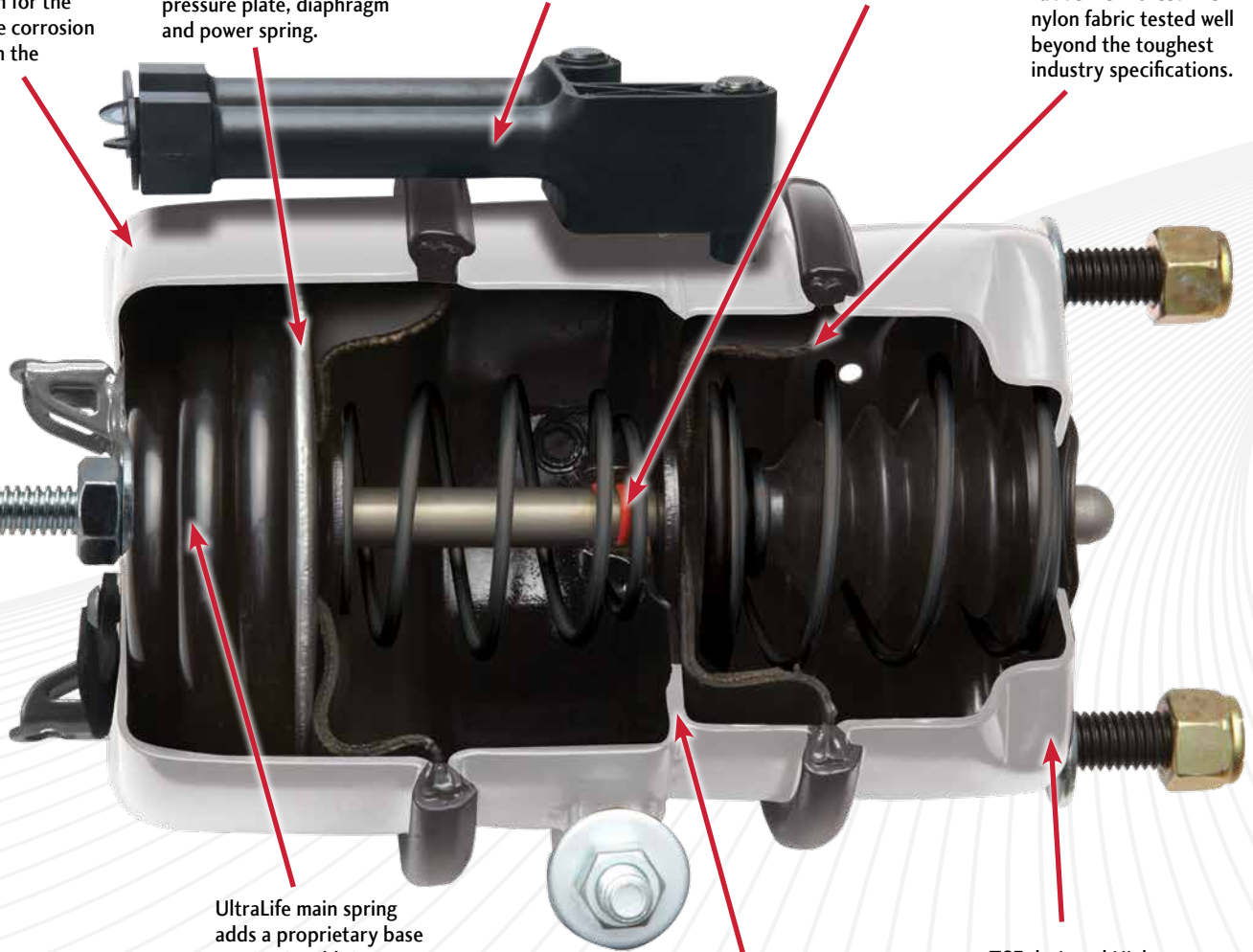

UltraLife main spring adds a proprietary base coating in addition to TSE's multi-stage coating system for the ultimate in corrosion protection.

All steel design provides durable, air tight center section that virtually eliminates leaks, structural failures and prevents galvanic corrosion.

TSE designed High Vibration "HV" mounting base reduces vibration for longer life standard on UltraLife products.



TSE Brakes, Inc.
2310 Industrial Drive S.W.
Cullman, Alabama 35055
256-736-6275
www.TSEbrakes.com