



hot high output
technology™

A More Powerful Spring Brake in a Smaller Package



As the first double-diaphragm chamber used worldwide for disc brake applications, TSE's High Output Technology (HOT) chamber is a proven alternative to piston type disc brakes. HOT chambers offer higher output performance for your S-cam drum brake and disc brake application when compared to standard double-diaphragm chambers, and at a lower cost than piston chambers. HOT brakes are ideal for replacing piston brakes that are typically used on buses and other severe-duty applications.

Patented Design

Featuring a lighter weight and smaller envelope size, the HOT brake's patented housing design, HOT diaphragm and HOT pressure plate increase performance while improving effective surface area. In addition, internal dust boot and optional rod guide ensure longer service life and improved protection against corrosion. A reduced profile (RP) design is available for special fitment needs, where every millimeter counts.

Powerful Parking Performance

Achieve a higher parking or emergency force in a smaller profile while maintaining low hold-off pressure with a HOT brake. Also ideal for other severe-duty applications where you need higher parking force for added safety.

Corrosion Protection

All steel HOT brakes receive TSE's in-house full immersion e-coating to ensure 100% coating for the best corrosion protection.

Size/Stroke

HOT chambers are available in a 2.5" or 3" (65mm or 76mm) stroke, with US or metric threads for ports and mounting hardware.

In-House Testing Lab

HOT chambers receive extensive testing through TSE's in-house lab for optimum performance, including tests such as variable pressure cycle, vibration, hot cell cycle, salt spray and slurry.

Warranty

HOT chambers are available with a standard 3-year warranty, with an extended warranty available for National Fleet Partner customers.

hot **high output™**
technology

A More Powerful Spring Brake in a Smaller Package

Full immersion electro-deposition coating inside and out and an exclusive powder coating finish for the most durable corrosion protection in the industry.

Self-guided pressure plate assures consistent alignment of spring providing super smooth operation and less wear. Steel APR plate is e-coated to eliminate corrosion degradation.

Patented bushing assembly provides self lubricating center seal that traps lubricant for extended service, reducing center section leaks and brake drag.

Premium diaphragms feature high quality contaminate resistant rubber with nylon reinforced fabric tested well beyond the toughest industry specifications.

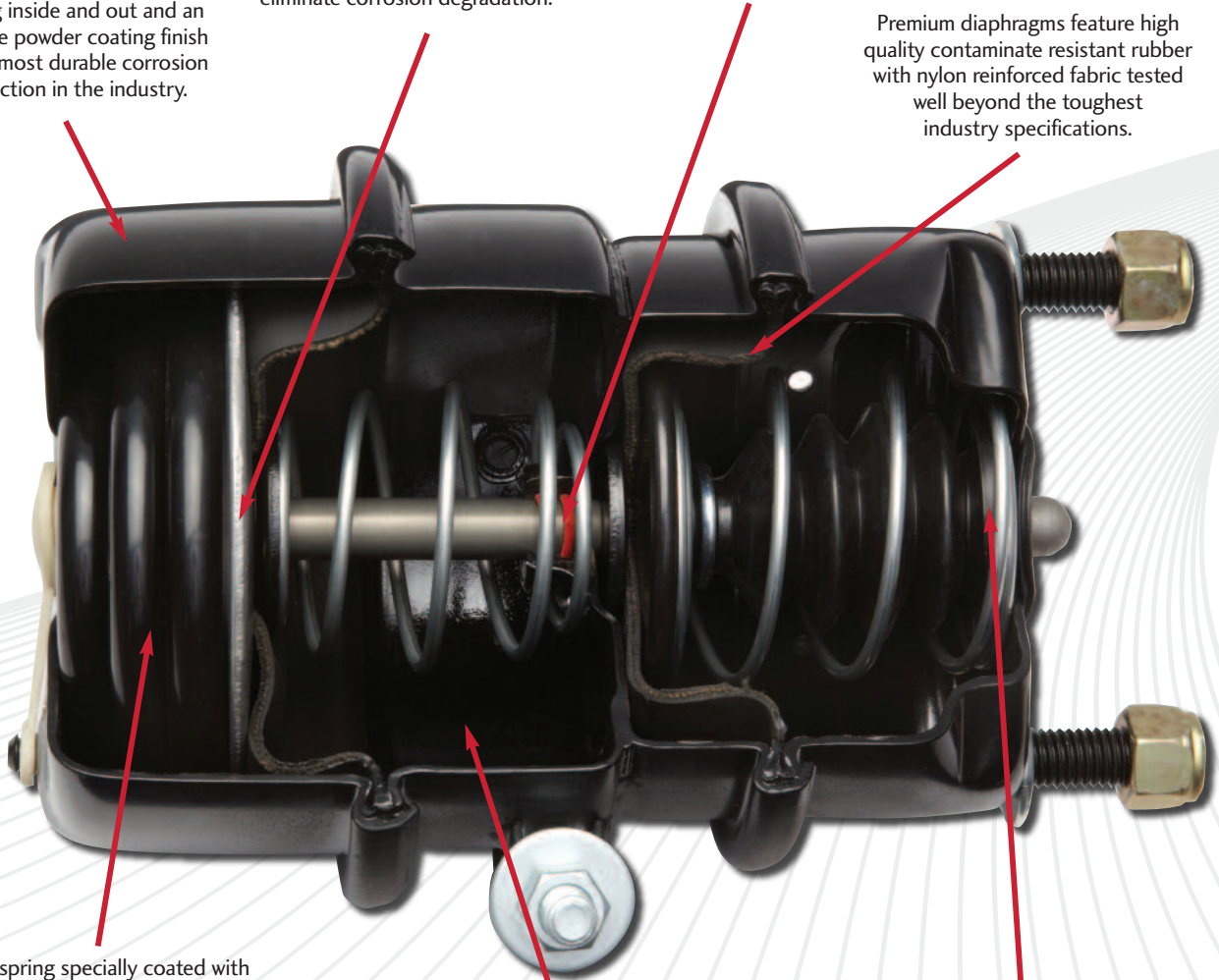

Main spring specially coated with zinc phosphate base then e-coated for superior corrosion protection.

All steel design provides durable, air tight center section that virtually eliminates leaks and structural failures.

TSE designed High Vibration "HV" mounting base reduces vibration for longer life. (T30 & 36 models).



TSE Brakes, Inc.

2310 Industrial Drive S.W.
Cullman, Alabama 35055

256-736-6275

www.TSEbrakes.com